

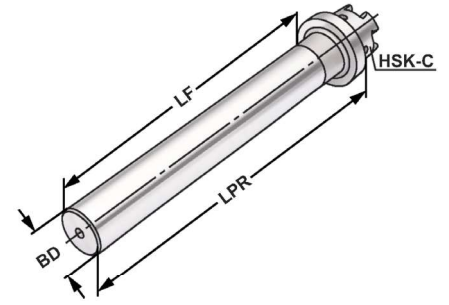

**Verwendung:**  
Zur Abnahme von Werkzeugmaschinen gemäß ISO-Empfehlung R230 oder zur Überprüfung der Werkzeugspindel.

**Application:**  
For the inspection of machine tools according to ISO recommendation R230 or for testing the tool spindle.

**Application:**  
Pour l'inspection de machine-outils suite à la recommandation ISO R230 ou pour la vérification de la broche.



ISO 12164	Form C	≤ 3µm
-----------	--------	-------

5

Bestell-Nr. Order no. Référence	HSK	BD	LPR	LF	Toleranz Tolerance Tolérance	max. Rundlaufabweichung max. concentricity deviation Faux-ronnd max.
C32.18.25	HSK-C 32	25	160	140	0,003	0,003
C40.18.25	HSK-C 40	25	160	140	0,003	0,003
C50.18.32	HSK-C 50	32	300	275	0,003	0,003
C63.18.40	HSK-C 63	40	300	275	0,003	0,003
C80.18.40	HSK-C 80	40	300	275	0,003	0,003
C100.18.50	HSK-C 100	50	300	275	0,003	0,003

**Lieferumfang:** Auslieferung mit Prüfprotokoll  
**Delivery:** Delivery with test certificate  
**Livraison:** Livraison avec rapport d essais

### Holzkasten für Kontrolldorne

Wooden box for test arbors  
Coffret en bois pour mandrins de contrôle



**Verwendung:**  
Zur Aufbewahrung von Kontrolldornen.

**Application:**  
For the storage of test arbors.

**Application:**  
Pour la conservation de mandrins de contrôle.



Bestell-Nr. Order no. Référence	Abmessung Size Dimension	für Kegelgrößen for cones pour cônes
701.18	460 × 130 × 115	HSK 32 / 40 / 50 / 63 / 80 / 100